

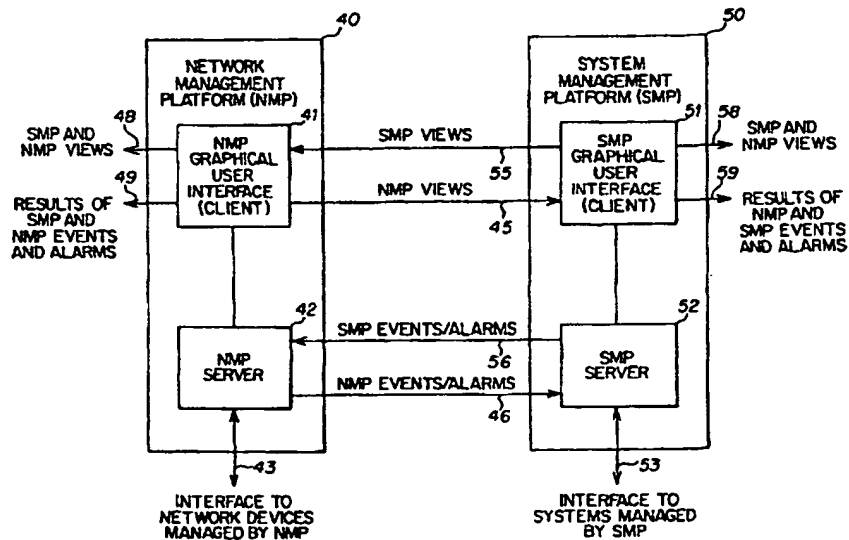

INTERNATIONAL APPLICATION PUBLISHED UNDER THE PATENT COOPERATION TREATY (PCT)

<p>(51) International Patent Classification ⁶ : H04L 12/24</p>	<p>A2</p>	<p>(11) International Publication Number: WO 97/44937 (43) International Publication Date: 27 November 1997 (27.11.97)</p>
<p>(21) International Application Number: PCT/US97/08043 (22) International Filing Date: 13 May 1997 (13.05.97) (30) Priority Data: 08/649,278 17 May 1996 (17.05.96) US (71) Applicant: CABLETRON SYSTEMS, INC. [US/US]; 35 Industrial Way, P.O. Box 5005, Rochester, NH 03867-5005 (US). (72) Inventors: LEWIS, Lundy; 480 Greenville Road, Mason, NH 03048 (US). ST. ONGE, David; 110A Chestnut Street, Pepperell, MA 01463 (US). MEHTA, Ruchika; 18 Cummings Road, Monmouth Junction, NJ 08852 (US). (74) Agent: HENDRICKS, Therese, A.; Wolf, Greenfield & Sacks, P.C., 600 Atlantic Avenue, Boston, MA 02210 (US).</p>		<p>(81) Designated States: AL, AM, AT, AU, AZ, BA, BB, BG, BR, BY, CA, CH, CN, CU, CZ, DE, DK, EE, ES, FI, GB, GE, HU, IL, IS, JP, KE, KG, KP, KR, KZ, LC, LK, LR, LS, LT, LU, LV, MD, MG, MK, MN, MW, MX, NO, NZ, PL, PT, RO, RU, SD, SE, SG, SI, SK, TJ, TM, TR, TT, UA, UG, UZ, VN, ARIPO patent (GH, KE, LS, MW, SD, SZ, UG), Eurasian patent (AM, AZ, BY, KG, KZ, MD, RU, TJ, TM), European patent (AT, BE, CH, DE, DK, ES, FI, FR, GB, GR, IE, IT, LU, MC, NL, PT, SE), OAPI patent (BF, BJ, CF, CG, CI, CM, GA, GN, ML, MR, NE, SN, TD, TG).</p> <p>Published <i>Without international search report and to be republished upon receipt of that report.</i></p>

(54) Title: METHOD AND APPARATUS FOR INTEGRATED NETWORK MANAGEMENT AND SYSTEMS MANAGEMENT IN COMMUNICATIONS NETWORKS



(57) Abstract

A computer system includes a gateway which provides integration between a network management platform and a system management platform. Such a gateway facilitates sharing of network management and system management events and alarms, as well as sharing of network management and system management display views. From the shared events and alarms, each platform may correlate such shared events and alarms with other data available to the platform. Thus, each platform has the advantage of using its own data in combination with data from the other platform to more effectively perform its functionality.

FOR THE PURPOSES OF INFORMATION ONLY

Codes used to identify States party to the PCT on the front pages of pamphlets publishing international applications under the PCT.

AL	Albania	ES	Spain	LS	Lesotho	SI	Slovenia
AM	Armenia	FI	Finland	LT	Lithuania	SK	Slovakia
AT	Austria	FR	France	LU	Luxembourg	SN	Senegal
AU	Australia	GA	Gabon	LV	Latvia	SZ	Swaziland
AZ	Azerbaijan	GB	United Kingdom	MC	Monaco	TD	Chad
BA	Bosnia and Herzegovina	GE	Georgia	MD	Republic of Moldova	TG	Togo
BB	Barbados	GH	Ghana	MG	Madagascar	TJ	Tajikistan
BE	Belgium	GN	Guinea	MK	The former Yugoslav Republic of Macedonia	TM	Turkmenistan
BF	Burkina Faso	GR	Greece	ML	Mali	TR	Turkey
BG	Bulgaria	HU	Hungary	MN	Mongolia	TT	Trinidad and Tobago
BJ	Benin	IE	Ireland	MR	Mauritania	UA	Ukraine
BR	Brazil	IL	Israel	MW	Malawi	UG	Uganda
BY	Belarus	IS	Iceland	MX	Mexico	US	United States of America
CA	Canada	IT	Italy	NE	Niger	UZ	Uzbekistan
CF	Central African Republic	JP	Japan	NL	Netherlands	VN	Viet Nam
CG	Congo	KE	Kenya	NO	Norway	YU	Yugoslavia
CH	Switzerland	KG	Kyrgyzstan	NZ	New Zealand	ZW	Zimbabwe
CI	Côte d'Ivoire	KP	Democratic People's Republic of Korea	PL	Poland		
CM	Cameroon	KR	Republic of Korea	PT	Portugal		
CN	China	KZ	Kazakstan	RO	Romania		
CU	Cuba	LC	Saint Lucia	RU	Russian Federation		
CZ	Czech Republic	LI	Liechtenstein	SD	Sudan		
DE	Germany	LK	Sri Lanka	SE	Sweden		
DK	Denmark	LR	Liberia	SG	Singapore		
EE	Estonia						

**METHOD AND APPARATUS FOR INTEGRATED
NETWORK MANAGEMENT AND SYSTEMS
MANAGEMENT IN COMMUNICATIONS NETWORKS**

5

BACKGROUND OF THE INVENTION

1. **Field of the Invention**

10

This invention relates generally to computer systems, and more particularly, to platforms that monitor communications networks, platforms that monitor computer system operation, and integration and sharing information between the two types of platforms.

15 2. **Discussion of the Related Art**

Computer networks are widely used to provide increased computing power, sharing of resources and communication between users. Networks may include a number of computer devices within a room, building or site that are connected by a high-speed local data link such as token ring, Ethernet, or the like. Local area networks (LANs) in different locations may be interconnected by for example packet switches, microwave links and satellite links to form a wide area network (WAN). A network may include several hundred or more connected devices, distributed across several geographical locations and belonging to several organizations.

In the operation and maintenance of computer networks, a number of issues arise, including traffic overload on parts of the network, optimum placement and interconnection of network resources, security, isolation of network faults, and the like. These issues become increasingly complex and difficult to understand and manage as the network becomes larger and more complex. For example, if a network device is not sending messages, it may be difficult to determine whether the fault is in the device itself, a data communication link, or an intermediate network device between the sending and receiving devices.

30 Network management platforms, also referred to as network management systems, are intended to resolve such issues. Older network management platforms typically operated by collecting large volumes of information which then required evaluation by a network administrator, and thus placed a tremendous burden on and required a highly skilled network administrator.

35 Newer network management platforms systematize the knowledge of the networking expert such that common problems of a single domain (i.e., a portion of the network under

common management) can be detected, isolated and repaired, either automatically or with the involvement of less-skilled personnel. Such a platform typically includes a graphical representation of that portion of the network being monitored by the system. Alarms are generated to inform an external entity that an event has occurred and/or requires attention. Since
5 a large network may have many such events occurring simultaneously, some network management platforms provide alarm filtering.

Commercially available network management platforms and applications for alarm filtering include: (1) SPECTRUM®, Cabletron Systems, Inc., 35 Industrial Way, Rochester, New Hampshire 03867; (2) HP OpenView, Hewlett Packard Corp., 3000 Hanover Street, Palo
10 Alto, CA 94304; (3) LattisNet, Bay Networks, 4401 Great American Pkwy., Santa Clara, CA 95054; (4) IBM Netview/6000, IBM Corp., Old Orchard Road, Armonk, NY 10504; and (5) SunNet Manager, SunConnect, 2550 Garcia Ave, Mountain View, CA 94043.

System management platforms have been developed to provide insight into the operation of a device or a set of devices which may or may not be included in a network managed by a
15 network management platform. For example, a system management platform may provide a list of users that are currently logged onto the device, a list of logon attempts (including whether the logon attempt was successful, an identification of the user, and a time stamp), the number and status of disk partitions on a storage device within the device, indications of software applications that are currently running on the device, and file management information.

20 Examples of system management platforms include: (1) Tivoli, Tivoli Systems, Inc., 9442 Capital of Texas Highway North, Arboretum Plaza One, Suite 500, Austin TX 78759; (2) UniCenter, Computer Associates International, Inc., One Computer Associates Plaza, Islandia NY 11788-7000; (3) Calypso, Calypso Software Systems, 25 Sundial Avenue, Suite 205, Manchester NH 03103; and (4) BMC, BMC Software, Inc., 2101 City West Blvd., Houston TX
25 77042-2827.

Fig. 1 depicts generally the relationship between a network management platform and a system management platform. In Fig. 1, a communications network 10 includes device 12A, device 12B, device 12C and device 14A, which are coupled together by interface 15. Additionally, device 12C is also coupled to device 12D, device 12E, and device 14B via
30 communications interface 17.

As indicated by the dashed lines connecting the network management platform 21 to the communications network 10, the network management platform 21 monitors and manages

aspects of the communications network 10 that relate to data communications. For example, the network management platform 21 may poll network devices, gather communications statistics, analyze data, perform fault isolation and false alarm suppression, provide alarms relating to communications to users or to other applications, as well as other functions relating to the communications network.

In contrast to the functions performed by the network management platform 21, the system management platform 19 monitors and manages individual devices 12A-E that are part of the communications network 10. For example, the system management platform 19 provides user administration, print management, software distribution, job scheduling, security, and data backup for the devices 12A-E.

The network management platform 21 and system management platform 19 may reside on different computers, or require a system administrator to view the display of each platform separately, thus making it cumbersome for the administrator to efficiently use both platforms. It would be desirable if a network management platform could provide information currently provided by a system management platform, or if a system management platform could provide information currently provided by a network management platform. Additionally, it would be desirable if each platform could use data from the other platform in combination with other data to more effectively monitor and manage the respective management aspects for which each platform is responsible.

SUMMARY OF THE INVENTION

According to one aspect of the invention, a gateway provides integration between a network management platform and a system management platform. Such a gateway facilitates sharing of network management and system management events and alarms, as well as sharing of network management and system management display views. From the shared events and alarms, each platform may correlate such shared events and alarms with other data available to the platform. Thus, each platform has the advantage of using its own data in combination with data from the other platform to more effectively perform its functionality.

One embodiment of the invention is directed to a method for sharing information between a first management system and a second management system, the method comprising the steps of receiving a message from the first system, determining whether the message relates to an entity that is managed by the second management system, and formatting the message in a format

RECTIFIED SHEET (RULE 91)
ISA/EP

compatible with the second management system when the message relates to an entity that is managed by the second management system. The method may also include notifying the second management system that a message is available from the first management system.

Another embodiment of the invention is directed to a system for providing an interface
5 between a first management system and a second management system, comprising a correlator, a message formatter, and an interface module. The correlator has an input that receives a message from the first management system, and an output that provides a correlated message when the message is related to an entity managed by the second management system, and the message
10 formatter has an input that receives the correlated message and an output that provides a formatted message that is compatible with the second management system. The interface module has an output that provides a notification to the second management system when the output of the message formatter provides the formatted message.

In any of the embodiments described above, the first management system may include a network management platform and the second management system may include a system
15 management platform. The second management system may include a command line interface for invoking processes within the second management system, one of which may be invoked to notify the second management system that a message is available. Additionally, the formatted message may be sent to the second management system, which may include appending the text of the message to a file that is accessible by the second management system, the file including a
20 plurality of related messages, for example information relating to the entity that is managed by the second management system.

The severity of the message may also be determined, so that the message is formatted only when the severity is greater than a predetermined severity. Additionally, a display view may be provided from the first management system to the second management system, which
25 may include invoking a software application that performs functions of the first management system.

BRIEF DESCRIPTION OF THE DRAWINGS

Other features and advantages of the present invention shall appear from the following
30 description of an exemplary embodiment, said description being made with reference to the appended drawings, of which:

RECTIFIED SHEET (RULE 91)
ISA/EP

Fig. 1, described above, depicts the relationship between a network management platform and a system management platform;

Fig. 2 is a schematic illustration of the relationship between a network and a network management platform;

5 Fig. 3 is a view of a user interface of a network management platform such as that shown in Fig. 2;

Fig. 4 illustrates an embodiment of the invention, in which a network management platform and a system management platform share events, alarms, and display views;

10 Fig. 5 illustrates an embodiment of the invention in which a gateway provides the sharing of events, alarms, and display views between the network management platform and the system management platform illustrated in Fig. 4;

Fig. 6 is a block diagram of an embodiment of the gateway illustrated in Fig. 5;

Fig. 7 is a flow diagram depicting steps of a process which may be performed by the embodiment of the gateway shown in Fig. 6;

15 Fig. 8 is a block diagram of another embodiment of the gateway illustrated in Fig. 5, which provides probable cause files associated with each managed entity;

Fig. 9 shows an example of a correlation table such as that shown in Fig. 8;

Fig. 10 shows an example of a probable cause file such as that shown in Fig. 8;

20 Fig. 11 is a block diagram of an embodiment of the invention in which a gateway provides integration between a SPECTRUM NMP and a Tivoli SMP;

Fig. 12 is a block diagram of an embodiment of the invention in which a gateway provides integration between a SPECTRUM NMP and a Unicenter SMP; and

Fig. 13 is a block diagram of a general purpose computer which may be employed to implement embodiments of the invention.

25

DETAILED DESCRIPTION

In accordance with a specific embodiment of the present invention, a network management platform provides to a user data and views generated from data and views of a system management platform. Additionally, the network management platform provides data and views to the system management platform which the network management platform may then provide to a user. Each of the platforms may correlate the data received from the other

30

platform to facilitate high-level insight into the operation of a network or of a computer system that has previously not been feasible without highly skilled human intervention.

Fig. 2 is a block diagram illustrating generally the arrangement of a network management platform (NMP) 21 which monitors a live network 10 via a communication interface 22. In one
5 example, the network management platform 21 is SPECTRUM®, which includes a database of models relating to corresponding network entities and relationships among those entities. SPECTRUM includes a network interface and control module 24, a virtual network machine 26, and a user interface 28.

The SPECTRUM NMP continually monitors the network 10 and maintains a database of
10 information about devices within the network 10. The devices, also referred to as network entities, include not only hardware devices such as personal computers (PCS), workstations, hubs, routers, bridges, and repeaters, but also software applications. An understanding of the present invention is furthered by an understanding of a model-based network management platform such as SPECTRUM, which is described in U.S. Patent No. 5,261,044, issued
15 November 9, 1993 to R. Dev et al., and hereby incorporated by reference in its entirety. The SPECTRUM platform is commercially available and also described in various user manuals and literature available from Cabletron Systems, Inc., Rochester, New Hampshire.

In summary, SPECTRUM is a system for maintaining and processing information pertaining to the condition of the computer network and providing the same to a user, the
20 network including a plurality of network resources such as computer devices and software applications being executed on such devices. The system includes a virtual network machine 26, comprising a programmed digital computer, wherein a program is implemented using an object-oriented programming language such as C++, Eiffel, SmallTalk, and Ada. The virtual network machine 26 includes interrelated intelligent models of network entities and relations
25 between network entities, including a capability for acquiring network data pertaining to the condition of a network entity from the corresponding network entity, and for those entities not capable of being contacted, inferring their status from the status of other entities. The virtual network machine 26 maintains objects which include network data relating to the corresponding network entity and one or more inference handlers for processing the network data, the inference
30 handlers being responsive to changes occurring in the same and/or a different object. The network data can then be transferred to a user interface 28 coupled to the virtual network machine 26, for supplying the network data to a user.

Thus, the models may be implemented as software "objects" containing both "data" (attributes) relating to the corresponding network entity and one or more "inference handlers" (functions) for processing the data. See Grady Booch, "Object-Oriented Analysis And Design, With Applications," 2nd Edition, Benjamin/Cummings Publishing Co., Redwood City, CA, Chapter 2 (1994). The inference handlers may be initiated by predetermined virtual network events, such as a change in specified network data in the same model, a change in specified network data in a different model, and predefined events or changes in models or model relations. Information pertaining to the condition of the network resource can be obtained from the network entity by polling the resource, can be automatically received from the network resource without polling, or can be inferred from data contained in other models. An alarm condition may be generated when the network data meets a predetermined criteria. Events, alarms and statistical information from the virtual network may be stored in a database to be selectively displayed for the user.

The data in the SPECTRUM database may be used for generating topological displays of the network, showing hierarchial relationships between network devices, isolating a network fault, reviewing statistical information, as well as other functions.

The SPECTRUM network management platform allows for collective management of autonomous local area networks (LANs), with equipment from different vendors. It complies with the current Simple Network Management Protocol (SNMP) standards, and can also accommodate other standard and proprietary protocols. The virtual network machine preprocesses the raw information coming from the network entities through the network interface and control module in order to construct a model of the network's current status and performance characteristics. Network entities that cannot be directly communicated with (e.g., cables and buildings) can infer their status from the status of the entities connected to or contained within them. The virtual network machine provides a consistent interface for management applications to access any of the information in the model and thereby provides these applications with a unified view of the network.

In a SPECTRUM implementation, the SPECTROGRAPH® user interface provides a highly graphical multi-perspective view into the network model. The user interface enables the user to navigate through a landscape in which cables, networks, local area networks and even rooms show up as icons, and which icons indicate the health and performance characteristics of those elements. Many of these icons can be further queried for additional information. The main

function of the user interface 28 is to visually present to the user the model within the virtual network machine 26. It allows the user to navigate freely within the network model, only limited by the access rights assigned by the network administrator. The information can be accessed at varying degrees of detail, from a macro overview, down to the level of the devices and the cables which connect them. In addition to its navigation functions, the SPECTROGRAPH user interface provides an alarm management facility, an event log window, a reporting facility, a find facility, and other features.

An example of the alarm log view provided by the SPECTROGRAPH user interface 28 is illustrated in Fig. 3. The alarm log view 33 may include an area 30 for the listing of current alarms, and an area 32 for displaying information pertaining to a selected alarm. A user, such as a system administrator or a technician, may select a particular alarm in the listing of current alarms to obtain more information. A multi-function icon 34 representing the network device having the fault is displayed in area 32, with one or more text fields 36 and 38 which provide information regarding the cause of the alarm and the status of the device. By selecting specified areas of the icon 34, the user can obtain further information regarding the device for which an alarm is registered.

Alternatively, instead of or in combination with the user interface 28, information from the virtual network machine 26 may be provided directly to another computer program, or may be provided to a user such as a system administrator via electronic mail or a telephone message that is automatically transmitted.

One method for fault management in large communications networks is to use a "trouble-ticketing" system. This system provides a number of tools for use by network users, administrators, and repair and maintenance personnel. The basic data structure, a trouble-ticket, has a number of fields in which a user can enter data describing the parameters of an observed network fault. A trouble-ticket filled out by a user may then be transmitted by, for example, an electronic mail system to maintenance and repair personnel. A trouble-ticket describing a current network fault requiring attention or action is referred to as an outstanding trouble-ticket. When the network fault has been corrected, the solution to the problem, typically called a resolution, is entered into an appropriate data field in the trouble-ticket and the trouble-ticket is classified as being completed. The system stores completed trouble-tickets in memory and thus a library of such tickets is created, allowing users, administrators, and maintenance and repair personnel to refer to the same for assistance in determining solutions to future network faults.

An example of a trouble-ticketing system is the ACTION REQUEST system, developed by Remedy Corporation, Mountain View, California, and sold by Cabletron Systems, Inc., Rochester, New Hampshire. ARS Gateway™ is an application sold by Cabletron Systems, Inc., which incorporates the SPECTRUM and ACTION REQUEST Systems. The ARS GATEWAY application receives fault information from the SPECTRUM system and automatically generates and processes a trouble-ticket. The ARS GATEWAY application is further described in copending and commonly owned U.S. Serial No. 08/023,972 filed February 26, 1993 by Lundy Lewis, and entitled "Method and Apparatus For Resolving Faults In Communications Networks," which is hereby incorporated by reference in its entirety.

An improvement over prior network management platforms is implemented in SPECTRUM Alarm Notification Manager (SANM), which utilizes policy-based filters to create an alarm notification policy that may apply to alarms received from several instances of a network management platform. Such a system is further described in copending and commonly owned U.S. Serial Nos. 08/412,955 filed March 29, 1995 and 08/558,425 filed November 16, 1995 by Arrowsmith et al., and entitled "Method and Apparatus For Policy-Based Alarm Notification in a Distributed Network Management Environment," and are hereby incorporated by reference in their entirety.

Fig. 4 illustrates an embodiment of the invention, in which a network management platform 40 and a system management platform 50 share information so that a network administrator, system administrator, or any other user can view all associated data from either one of the platforms 40, 50. Additionally, because each platform 40, 50 has access to its own data as well as the other platform's data, the quality of information provided to an administrator or external software application may be improved.

In particular, the network management platform (NMP) 40 includes an NMP graphical user interface (GUI) 41, which also may be referred to as a "client" in client-server technology. One embodiment of the NMP client 41 is SPECTROGRAPH described above. The NMP also includes an NMP server 42, one embodiment of which is SPECTROSERVER described above. The NMP 40 also includes interface 43 which couples to network devices and entities that are managed or monitored by the NMP 40.

The system management platform (SMP) 50 includes an SMP graphical user interface 51, also referred to as a "client," as well as an SMP server 52, and an interface 53 which couples to systems managed by the SMP 50.

As shown in Fig. 4, the NMP client 41 receives SMP views 55 from the SMP client 51, and the SMP client 51 receives NMP views 45 from the NMP client 41. One embodiment of the views 45, 55 include display data so that a display from one of the platforms may be recreated on a display from the other of the platforms. Accordingly, the NMP 40 can now provide both the
5 NMP and SMP views 48, and the SMP 50 can now provide both the SMP and NMP views 58.

For example, the SMP 50 can display an NMP view such as that depicted in Fig. 3. Without the benefits of this invention, an administrator who was viewing a display of the SMP 50 would have had to log onto another computer in many circumstances to view a display of such an alarm view, or any other view of the NMP 40.

10 Additionally, the NMP server 42 receives SMP events and alarms 56 from the SMP server 52, and the SMP server 52 receives NMP events and alarms 46 from the NMP server 42. Each server 42, 52, can analyze this additional data and correlate it as required to provide analysis results that may not have been possible with each platform's respective data alone. For example, as a result of the reception and analysis of the SMP event and alarm data 56, the NMP
15 server 42 may provide more detailed analysis data to the NMP client 41, so that the NMP 40 can provide the results of SMP and NMP events and alarms 49 to an administrator or external software application. Similarly, as a result of the reception and analysis of the NMP event and alarm data 46, the SMP server 52 may provide more detailed analysis data to the SMP client 51, so that the SMP 50 can provide the results of NMP and SMP events and alarms 59.

20 The results 49, 59 represent information for an administrator that was not previously available. For example, the SMP 50 may detect that a computer from the network 10 is not operating efficiently, e.g. processing jobs on the computer using data from a storage device are not being completed. The SMP 50 may not have any more information relating to the diagnosis of such a situation. However, the NMP 40 may be aware that a router in the communication path
25 between the computer and the storage device has failed. If the NMP 40 provides this information (typically in the form of events or alarms) to the SMP 50, then the SMP 50 will have the information necessary to inform an administrator that the computer is operating correctly, and that it is only a router failure causing the processing jobs on the computer to go uncompleted. Without the integration of an SMP 40 and an NMP 50, such a correlation of data would not have
30 been communicated to the administrator, and the administrator may have used significant time and resources to solve a non-existent problem within the computer itself.

Similarly, the NMP 40 may detect that a network entity is unreachable by other entities on the network 10, but may have no further information regarding this performance degradation. As a result, the NMP may cause alarms to be sent to an administrator and may also invoke fault isolation of the network 10. However, the SMP 50 may have information that the unreachable
5 network entity has crashed (i.e., stopped operating) due to a corrupted disk partition, and may provide this information to the NMP 40. As a result of receiving this information, the NMP 40 will probably not send a network alarm to the administrator, and there is no need to fault isolate the network, because there is nothing wrong with the network itself. Instead, both the NMP 40 and the SMP 50 may provide accurate data, i.e. that a disk partition and not a network failure has
10 caused an entity to be unreachable.

Fig. 5 illustrates an exemplary embodiment of the invention that facilitates data sharing between the NMP 40 and the SMP 50. In particular, the NMP client 41 includes an SMP view activation module 44, and the SMP client 51 includes an NMP view activation module 54. Each view activation module 44, 54 may be represented by an additional icon displayed on a display
15 of the respective platform. For example, one of the views of the NMP client may display an icon labeled "system management platform view," and allow an administrator to invoke such a view by selecting and activating this icon using a mouse, keyboard, or other interface device, or by controlling a pull-down menu.

In one embodiment, the SMP view is created by invoking an instance of the SMP client
20 51 from within the NMP 40. In this embodiment, once the SMP view is displayed through the NMP client 41, the administrator may select additional SMP functions and views by selecting icons or providing commands to the SMP server 52 through the SMP view provided on the NMP 40. Similarly, the SMP 50 can provide NMP functions and views via the NMP view activation module 54.

As shown in Fig. 5, the NMP server 42 may include an NMP command line interface 47,
25 and the SMP server 52 may include an SMP command line interface 57. Such command line interfaces 47, 57 allow an external user or device to control aspects of the associated platform by providing specific commands. For example, the NMP server 42 may include many software modules, each of which is usually invoked by one of the other software modules. A command
30 line interface 47 allows a user or external application to enter a command that directly invokes a particular one of these software modules, thus providing interface with external entities.

The embodiment shown in Fig. 5 also includes an NMP/SMP gateway 60, that provides a data path for the NMP/SMP events/alarms 46, 56, as well as for the NMP/SMP views 45, 55. The NMP/SMP gateway interfaces directly with the NMP command line interface 47 and with the SMP command line interface 57. As shown in Fig. 5, the NMP/SMP gateway may reside partially within the NMP server 42, partially within the SMP server 52, and partially external to both the NMP 40 and the SMP 50. However, in different embodiments, the NMP/SMP gateway 60 may reside entirely on one or the other of the platforms, may reside external to both platforms, or any combination thereof.

Fig. 6 is a block diagram of an embodiment of the gateway illustrated in Fig. 5. Such an embodiment includes a correlator 64 coupled to a severity filter 65, which is further coupled to a message formatter 66. This embodiment of the gateway 60 also includes an event/alarm status module 68 and a view interface 69, both of which are coupled to the command line interface controller 67. The command line interface controller 67 is coupled to one of the command line interfaces 47, 57, of one of the platforms 40, 50. In Fig. 6, the platform with the command line interface is referred to as the "second platform," indicative that it is receiving data from a first platform.

In operation, new events or alarms are received from the first platform by the correlator 64. Such events or alarms are correlated by the correlator to determine whether the events or alarms are of interest to the second platform. If so, the events or alarms are passed through the severity filter 65, which filters out less important events or alarms. Then, the message formatter 66 formats the events or alarms into a format that is compatible with the second platform 40, 50. The command line interface 67 invokes a command in the second platform command line interface 57, 47, so that the second platform is notified that a correlated message is available from the first platform. In addition to new events, existing events may be updated or cleared. In particular, the event/alarm status module 68 receives updates or clear information from the first platform, indicative of new information regarding an existing event or alarm. Such information is processed by the event/alarm status module 68 and passed to the command line interface controller 67 for notification of the second platform. Upon receipt of new information, update information, or clear information regarding the network monitored by the first platform, the second platform may correlate such data with its own data as described above. The correlation performed by the second platform 50, 40 is different from the correlation performed by the correlator 64, in that the second platform may use the data from the first platform in combination

with data already obtained by the second platform, to perform functions such as fault isolation analysis.

The first platform may also provide platform view data to the view interface 69, for example in response to the NMP view activation 54 being selected, which may cause a view data request to be sent to the view interface 69. After receiving such view data, the view interface 69 provides data to the command line interface controller 67, which in turn notifies the second platform 50, 40 of the available view data. The view data may be in the form of a bitmap file, or any other format which may be displayed by the second platform.

Fig. 7 is a flow diagram depicting detailed steps of a process performed by the embodiment of the gateway shown in Fig. 6. Fig. 6 shows that step 70 is performed within the first management platform 40, 50, which may be either a system management platform 40 or a network management platform 50. Steps 78-81 are performed within the second management platform 50, 40. Steps 71-77 are performed by a gateway 60, but as discussed above the gateway functions may also be provided within the first or second management platform.

In step 70, the first management platform 40, 50 generates an event or alarm message. Such a message may be a textual version of an alarm as described above with respect to SPECTRUM alarms, or may be any message generated as a result of monitoring a network or system. In step 71, the gateway receives the event or alarm message. The message is correlated to determine whether the associated event/alarm relates to a system that is managed by the second management platform 50, 40 (step 72). Such correlation may use a correlation table 73, which provides a map of events and alarms to systems managed by the second platform 50, 40. An example of such a correlation table 73 is a list of systems managed by the second platform 50, 40, along with an identifier for each system of events, alarms, or other messages which may relate to each respective system on the list. When a message is received, the correlation table 73 may be searched to determine whether the table 73 contains such a message.

If the message does not correlate with any system managed by the second management platform 50, 40, the process may be terminated. If there is a correlation, however, in step 74 it is determined whether the event or alarm has a severity that is greater than a predetermined severity. Such a function may be useful for filtering out less important messages. To support a severity determination, a first/second platform severity map 75 provides an indication of whether a message should be passed or filtered out depending upon the severity of the message. For example, a management platform may associate a severity of either FATAL, CRITICAL,

MINOR, or WARNING with each message. The gateway may filter out messages having a severity of either MINOR or WARNING, which represent less severe messages.

Once it is determined that a message correlates with a system managed by the second management platform 50, 40 and has a severity greater than a predetermined severity, a new message is created in step 76, the new message being in a format which is compatible with the second management platform 50, 40. In step 77, the formatted event/alarm message is sent to the second management platform 77. As indicated above, the second management platform 50, 40 may be notified that a formatted message exists via interface with a command line interface. Additionally, to provide the formatted message itself, the gateway may write the formatted message data to memory that is accessible by the second management platform.

In step 78, the second management platform 50, 40 receives the formatted event/alarm message, and in step 79 the formatted message is correlated as required with other data. As described above, the formatted message received from the first management platform 40, 50 may be analyzed in step 80 by the second management platform 50, 40, in conjunction with other data that is already available to the second management platform 50, 40. In step 81, the second management platform may display results, take corrective action, or send an alarm as a result of the analysis performed in step 80. An example of a corrective action taken by an NMP 40 would be to re-route messages to avoid a failed router. An example of corrective action taken by an SMP 50 would be to avoid failed disk space.

One embodiment of the invention includes a file of related messages that the gateway provides for access by the second management platform 50, 40. Such a file of related messages, referred to as a "probable cause file," is shown in Fig. 8. In particular, Fig. 8 shows portions of the gateway 60 similar to those shown in Fig. 6, but also shows an event/alarm status module 85 that creates such probable cause files. The message formatter 66, command line interface controller 67, and view interface 69 are omitted from the block diagram of Fig. 8 for clarity.

New alarms or events that pass through the correlator 64 and severity filter 65 are provided to the event/alarm status module 85, as is the information relating to update and clearing of existing events and alarms. In response, the event/alarm status module 85 creates and maintains a plurality of probable cause files 82A, 82B, ... 82N.

In one embodiment, each probable cause file 82 A-N is associated with a particular network entity, for example a server, router or computer. As new events are received that are related to this particular network entity, as determined by the event/alarm status module 85

querying the correlation table 84, the messages relating to the new events may be appended to the probable cause file 82. Thus, the probable cause file contains a history of information relating to the health and performance of the particular network entity. If an update to an event is received by the event/alarm status module 85, then the appropriate entry in the respective
5 probable cause file is updated. Additionally, if a message is received by the event/alarm status module 85 indicating that an event or alarm should be cleared, the contents of the probable cause file 82 may be erased, or a new entry may be made indicating that no problem currently exists.

The correlation table 84 may contain information as described above with respect to the correlation table 73 of Fig. 7, and may also contain additional information. An embodiment of
10 such a correlation table 84 is shown in Fig. 9. In particular, Fig. 9 illustrates that a correlation table 84 may include several entries 97, 98, 99, one for each model. In this example, the term "model" refers to any particular network entity or device monitored by an NMP 40 or SMP 50. The model entries 97, 98, 99 are provided in rows of the correlation table 84. The columns of the correlation table represent information relating to the particular model. Column 90 includes a
15 host name or model name, for example the model name "sparkplug" shown in row 97, and column 91 includes the model name as known by the SPECTRUM NMP. Column 92 gives the IP (Internet Protocol) address of the model. Column 93 provides the probable cause file 82 associated with the model identified in column 90. For example, probable cause file Prob01550000 is associated with the model "sparkplug," and thus contains associated message
20 data as described above. Column 94 provides a cause code indicative of which file to associate with a particular alarm. Other cause codes may be used by SPECTRUM for alarms that are not associated with SMP events or alarms. Column 95 provides a SPECTRUM model handle of the parent group to which the particular model belongs. For example, parent model handle 0xe8004 may identify a subnet to which the model "sparkplug" belongs within the network 10. As shown
25 in Fig. 9, many specific models may belong to a single parent.

From the information provided by the correlation table 84, the event/alarm status module 85 can determine which probable cause file 82 is associated with a particular model, so that the appropriate probable cause file 82 may be updated and maintained. The probable cause files 82A-N may reside in memory that is shared between the gateway 60 and the second platform 50,
30 40, so that the second platform 50, 40 may access these files.

Fig. 10 illustrates an example of a probable cause file 82. In this example, three messages 101, 102, 103 have been received and entered by the event/alarm status module. Each

entry begins with an event identifier 104. This example of the event identifier 104 includes a concatenation of three separate fields: an event handle which identifies the event; a server handle identifying the server that provided the message; and a date of reception indicative of the date in which the message was received. The date on which the message was written to the probable
5 cause file 82 is also provided, along with the text of the message (describing the effected network entity and problem), and a severity indication. From this data, the second platform 50, 40 may correlate and provide additional analysis as described above.

One embodiment of the invention includes a SPECTRUM/Tivoli gateway, which integrates the SPECTRUM NMP with the Tivoli SMP. A block diagram of the
10 SPECTRUM/Tivoli gateway 110 is depicted in Fig. 11.

In particular, the SPECTRUM NMP 111 includes the SPECTROGRAPH NMP client 112 and the SPECTROSERVER NMP server 113, which in turn includes an Alarm Notifier/Alarm Monitor 114 and a Command Line Interface 115. The SPECTROSERVER NMP server 113 interfaces with a managed network as described above, and may include either alarm
15 notifier software or alarm monitor software.

The Tivoli SMP 117 includes "Tivoli/Enterprise Console" SMP client 118 and a Tivoli SMP server 119, which in turn includes a Tivoli Rules Engine 120. The Tivoli SMP Client 118 interfaces with managed systems as described above.

In this embodiment, the gateway 110 includes a collection of executable files to perform
20 the functions described above, including providing the associated probable cause files 116A, 116B, 116C, ..., 116N. In general, a separate executable file may be provided for each function of the gateway and for each direction in which the data is being passed. For example, one executable file may provide event correlation for events received from the Tivoli SMP server 119, while another executable file may provide event correlation for events and alarms received
25 from the SPECTROSERVER NMP server 113.

In addition to the functions described above, an executable file may be provided to update correlation tables. For example, if a new device is added to the network, a representation of such a new device may be added to the appropriate correlation table. Similarly, representations of devices may be updated and removed. Additionally, in this instance, an executable file may be
30 provided to resolve differences in parameters in the event/alarm messages of each of the servers 113, 119. Generally such a file may be implemented with a number of conditional statements.

However, if the parameter differences were complex, then a parameter table may be provided to assist in the difference resolution.

Another embodiment of the invention, shown in Fig. 12, includes a SPECTRUM/Unicenter gateway 121, which integrates the SPECTRUM NMP with the Unicenter SMP. As with the embodiment described with respect to Fig. 11, the SPECTRUM NMP 111 includes the SPECTROGRAPH NMP client 112 and the SPECTROSERVER NMP server 113. Additionally, the Unicenter SMP may include a Unicenter SMP client 122 and a Unicenter/Event server 123. Fig. 12 also includes a representation of the network 10 including systems monitored by both the SPECTROSERVER NMP server 113 and the Unicenter/Event SMP server 123.

The block diagram of Fig. 12 also provides an example of shared networks and network devices. In particular, the network of Fig. 12 includes computer 124A, computer 124B, computer 124C, printer 126, and bridge 127, all of which are physically connected to linear interface 125A. Bridge 127 is also connected to linear interface 125B, which provides communications among computer 124D, computer 124E, and router 128. Router 128 is also connected to ring interface 125C, which provides communications among computer 124F, computer 124G, computer 124H, and computer 124I.

As described herein, network information 131 is received by the SPECTROSERVER NMP server 113, while system information 129 is received by the Unicenter/Event SMP server 123. The SPECTRUM/Unicenter Gateway 121 provides selective event and alarm sharing between the two servers 113, 123. Additionally, each client may access display data of the other client through menu, icon, or keyboard selections.

The embodiments of the NMP, SMP, and gateway described herein may be implemented in specially-designed hardware such as a state machine or other digital circuitry, or in any of several programming languages on a general purpose computer, or as a programmed general purpose computer itself.

For example, elements of the NMP, SMP, or gateway may be implemented as software on a floppy disk, compact disk, or hard drive, which controls a computer, for example a general purpose computer such as a workstation, a mainframe or a personal computer, to perform steps of the disclosed processes or to implement equivalents to the disclosed block diagrams. Such a general purpose computer 130, shown in Fig. 13, typically includes a central processing unit 132

(CPU) coupled to random access memory (RAM) 134 and program memory 136 via a data bus 138. The general purpose computer 130 may be connected to the network 10 in order to

interface with other elements, and may provide commands to devices on the network in order to control the network configuration by an NMP 40 or to control a system managed by an SMP 50.

Alternatively, the elements of the embodiments described herein may be implemented as special purpose electronic hardware. Additionally, in either a hardware or software embodiment, 5 the functions performed by these different elements may be combined in varying arrangements of hardware and software.

Having thus described at least one illustrative embodiment of the invention, various modifications and improvements will readily occur to those skilled in the art and are intended to be within the scope of the invention. Accordingly, the foregoing description is by way of 10 example only, and not intended to be limiting.

CLAIMS

1. A method for sharing information between a first management system and a second management system, the method comprising the steps of:
- 5 (a) receiving a message from the first management system;
- (b) determining whether the message relates to an entity that is managed by the second management system;
- (c) when the message relates to an entity that is managed by the second management system, formatting the message in a format compatible with the second management system; and
- 10 (d) notifying the second management system that a message is available from the first management system.
2. The method of claim 1, wherein the second management system includes a command line interface for invoking processes within the second management system, and wherein step (d)
- 15 includes invoking one of the processes by accessing the command line interface.
3. The method of claim 1, further comprising a step (e) of sending the message, in the format compatible with the second management system, to the second management system.
- 20 4. The method of claim 3, wherein step (e) includes appending text of the message to a file that is accessible by the second management system, the file including a plurality of related messages.
5. The method of claim 4, wherein each of the plurality of related messages includes
- 25 information relating to the entity that is managed by the second management system.
6. The method of claim 3, further comprising the step performed by the second management system of:
- correlating data from the message with other data available to the second management
- 30 system.

7. The method of claim 1, further comprising the steps of:
determining a severity of the message; and
comparing the severity of the message to a predetermined severity;
and wherein step (c) is performed only when the severity of the message is greater than
5 the predetermined severity.

8. The method of claim 1, further comprising the steps of:
receiving a request from the second management system to provide a display view from
the first management system; and
10 providing, to the second management system, data that represents the display view from
the first management system.

9. The method of claim 8, wherein the step of providing includes invoking a software
application that performs functions of the first management system.
15

10. The method of claim 1, wherein the first management system includes a network
management platform and the second management system includes a system management
platform.

20 11. An apparatus for sharing information between a first management system and a
second management system, the apparatus comprising:
first means for receiving a message from the first management system;
second means for determining whether the message relates to an entity that is managed
by the second management system;
25 third means for formatting the message in a format compatible with the second
management system when the message relates to an entity that is managed by the second
management system; and
fourth means for notifying the second management system that a message is available
from the first management system.

30

12. The apparatus of claim 11, wherein the second management system includes a command line interface for invoking processes within the second management system, and wherein the fourth means includes means for invoking one of the processes by accessing the command line interface.

5

13. The apparatus of claim 11, further comprising fifth means for sending the message, in the format compatible with the second management system, to the second management system.

14. The apparatus of claim 13, further comprising sixth means for correlating data from
10 the message with other data available to the second management system.

15. The apparatus of claim 13, wherein the fifth means includes means for appending text of the message to a file that is accessible by the second management system, the file including a plurality of related messages.

15

16. The apparatus of claim 15, wherein each of the plurality of related messages includes information relating to the entity that is managed by the second management system.

17. The apparatus of claim 11, further comprising:
20 means for determining a severity of the message; and
means for comparing the severity of the message to a predetermined severity;
and wherein the third means includes means for formatting the message only when the severity of the message is greater than the predetermined severity.

18. The apparatus of claim 11, further comprising:
25 means for receiving a request from the second management system to provide a display view from the first management system; and
means for providing, to the second management system, data that represents the display view from the first management system.

30

19. The apparatus of claim 18, wherein the means for providing includes means for invoking a software application that performs functions of the first management system.

20. The apparatus of claim 11, wherein the first management system includes a network management platform and the second management system includes a system management platform.

5 21. A system for providing an interface between a first management system and a second management system, comprising:

a correlator, having an input that receives a message from the first management system, and an output that provides a correlated message when the message is related to an entity managed by the second management system;

10 a message formatter, coupled to the correlator, having an input that receives the correlated message and an output that provides a formatted message in a format that is compatible with the second management system; and

an interface module, coupled to the correlator and the second management system, having an output that provides a notification to the second management system when the output of the message formatter provides the formatted message.

15

22. The system of claim 21, wherein the interface module includes a command line interface controller, the command line interface controller invoking a process within the second management system to provide the notification to the second management system.

20

23. The system of claim 21, further comprising a status module, coupled to the message formatter, having an input that receives the formatted message and an output that provides the formatted message to the second management system.

25 24. The system of claim 23, wherein the status module provides the formatted message by appending text of the formatted message to a file that is accessible by the second management system, the file including a plurality of related messages.

25. The system of claim 24, wherein each of the plurality of related messages includes information relating to the entity that is managed by the second management system.

30

26. The system of claim 21, further comprising a severity filter having an input coupled to the output of the correlator, and an output coupled to the input of the message formatter, the severity filter determining a severity of the correlated message and providing the correlated message to the message formatter only when the severity of the formatted message is greater
5 than a predetermined severity.

27. The system of claim 21, further comprising a view interface having an output that provides, to the second management system, data that represents a display view of the first management system.

10

28. The system of claim 21, wherein the first management system includes a network management platform and the second management system includes a system management platform.

15

29. The system of claim 21, wherein the system includes a plurality of executable files that may be initiated by the first management system and the second management system.

30. The system of claim 23, further comprising a correlator for correlating data in the formatted message with other data available to the second management system.

20

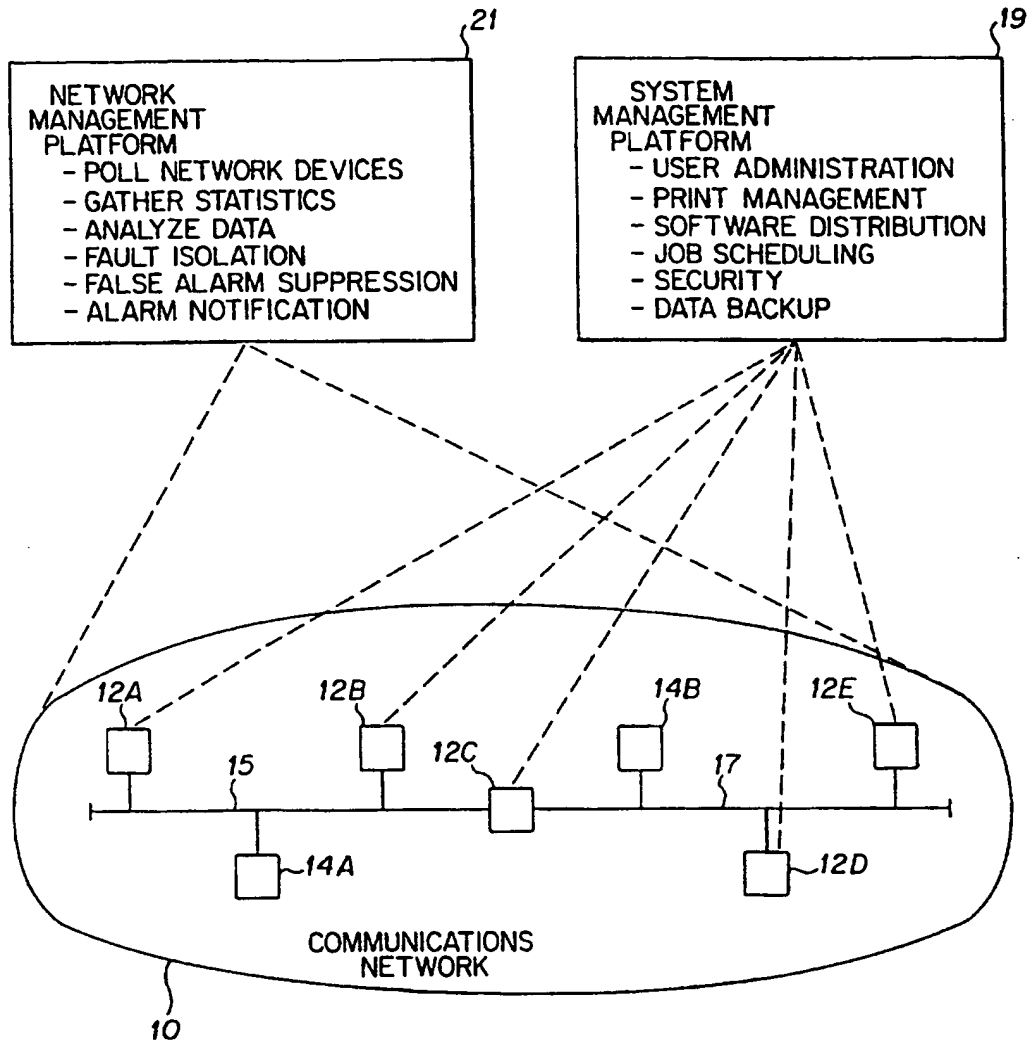

FIG. 1

SUBSTITUTE SHEET (RULE 28)

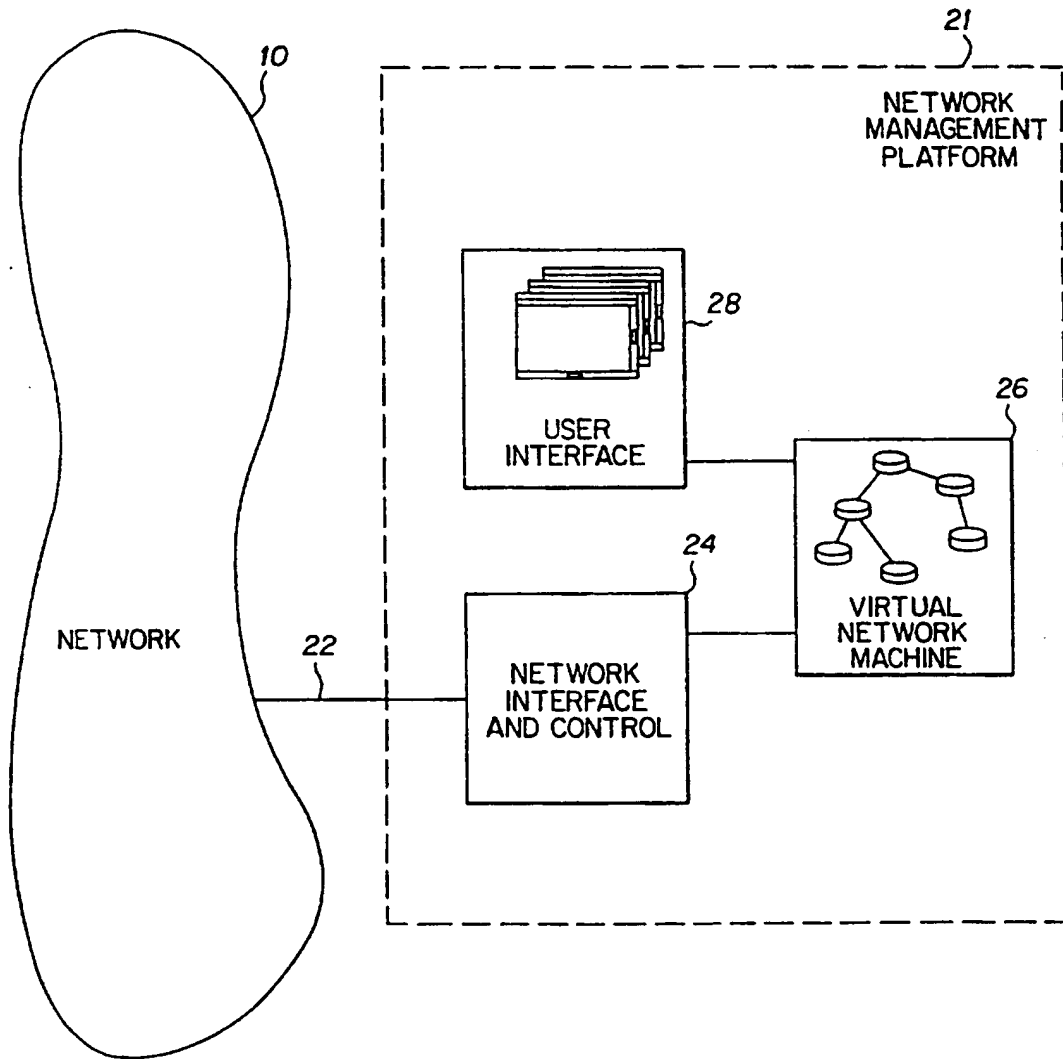

FIG. 2

SUBSTITUTE SHEET (RULE 28)

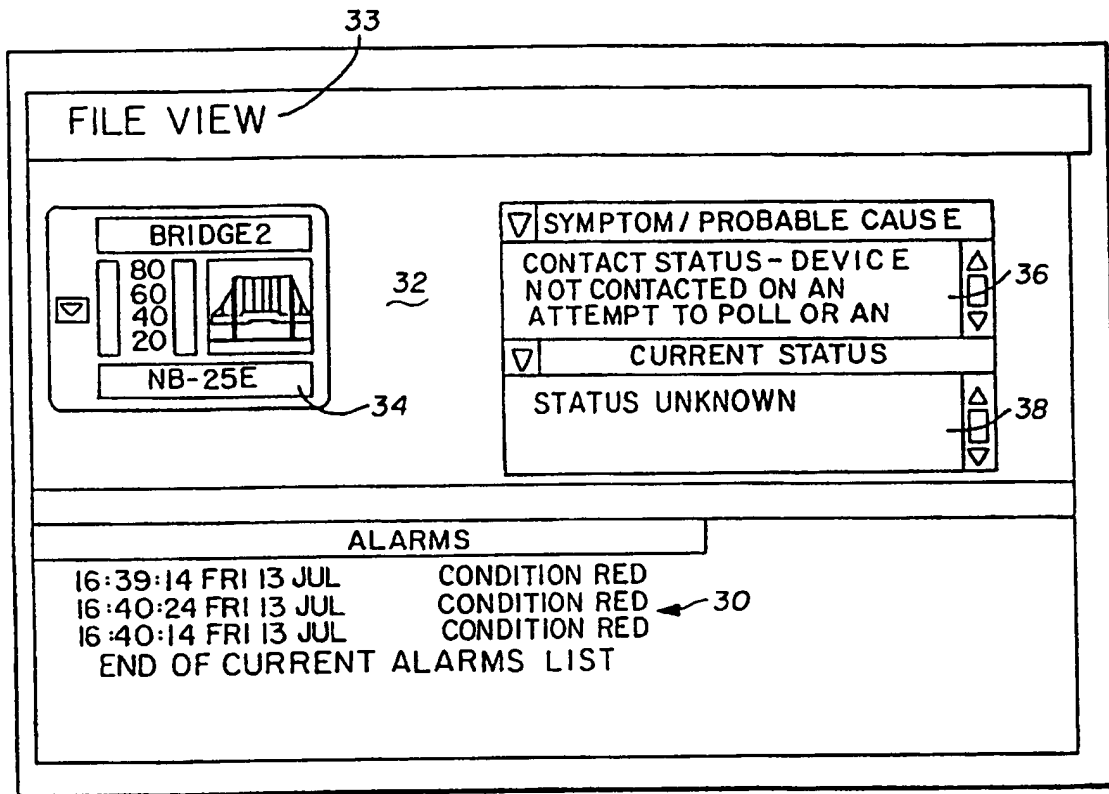

FIG. 3

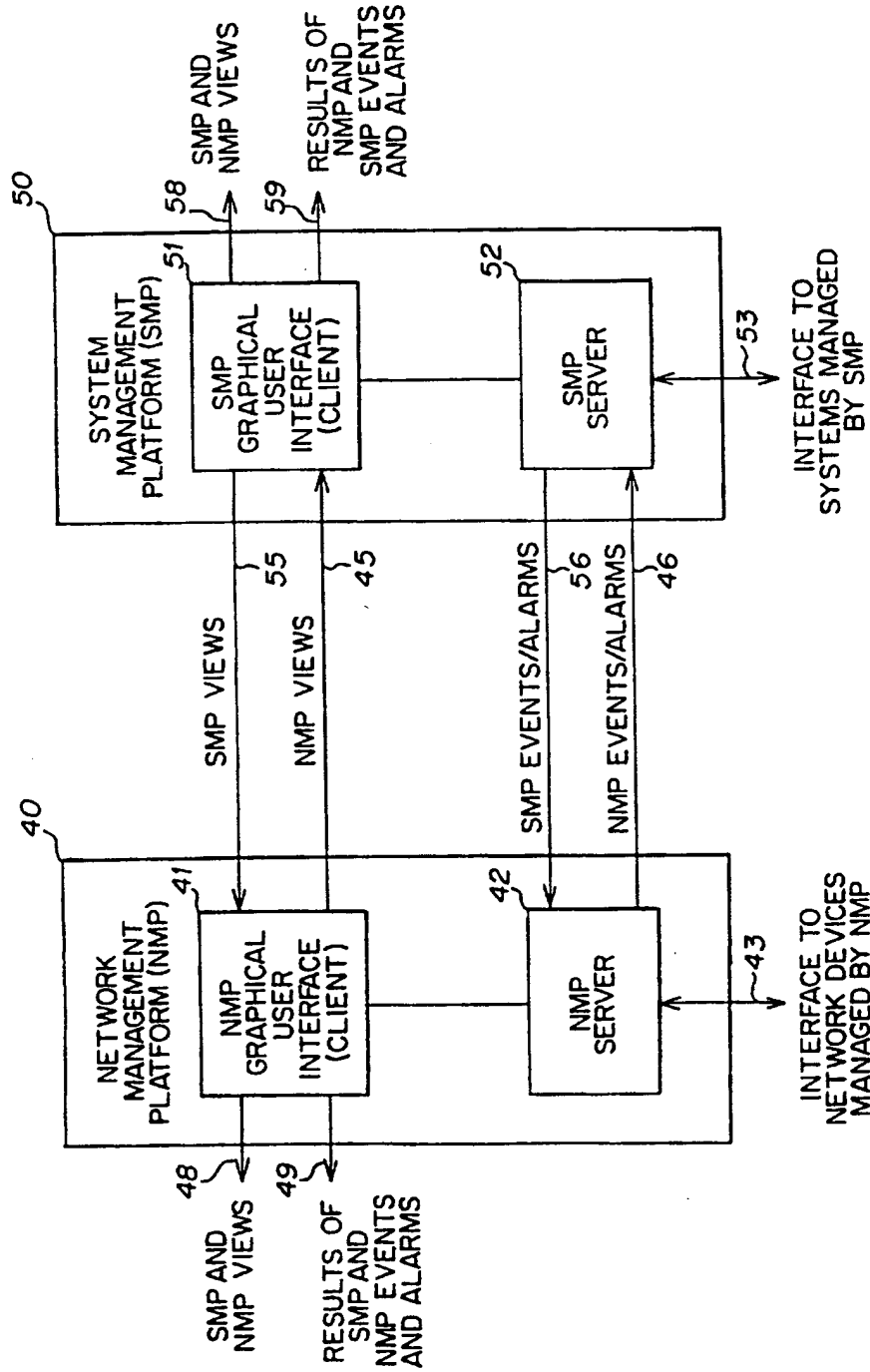

FIG. 4

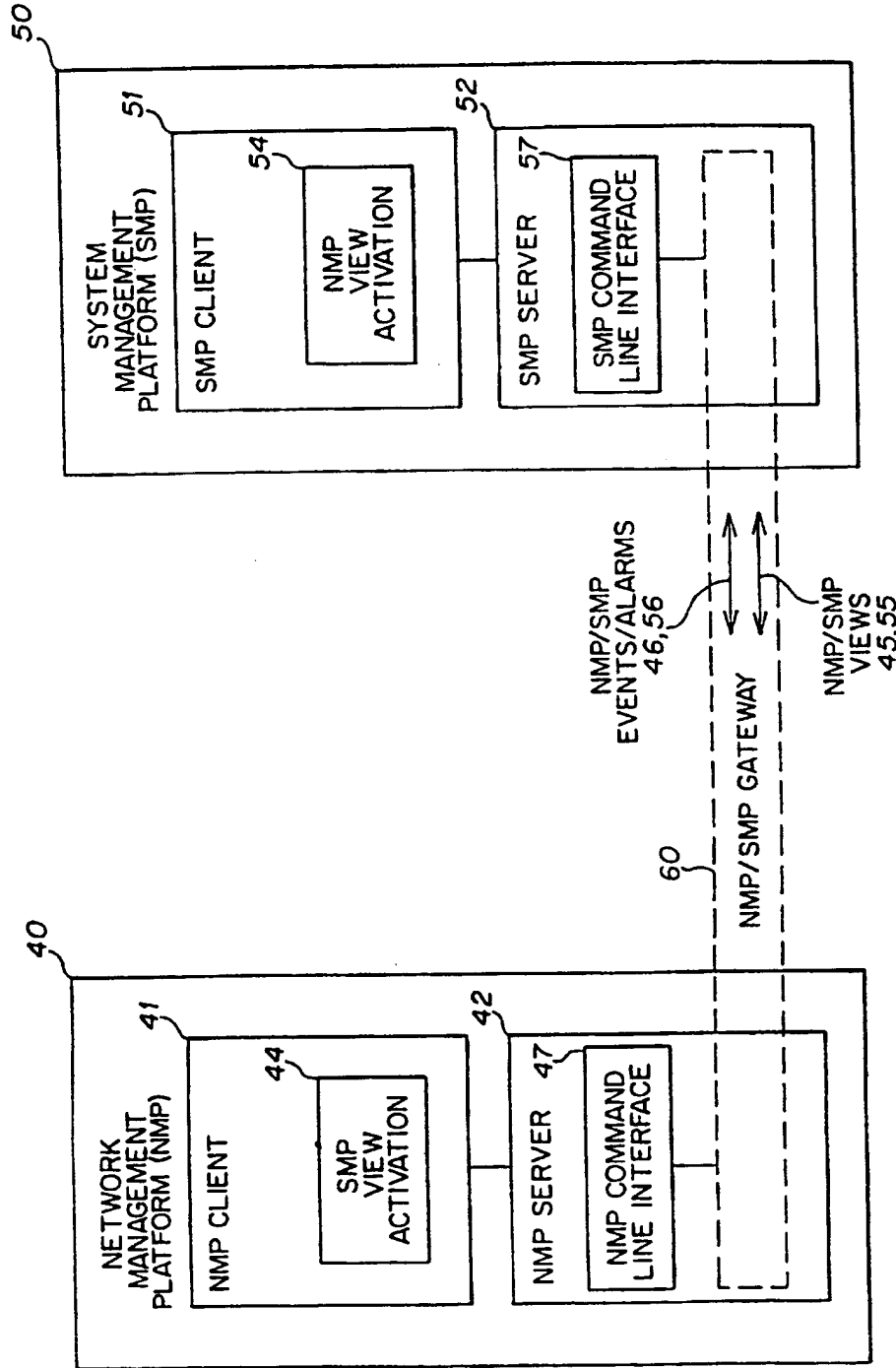

FIG. 5

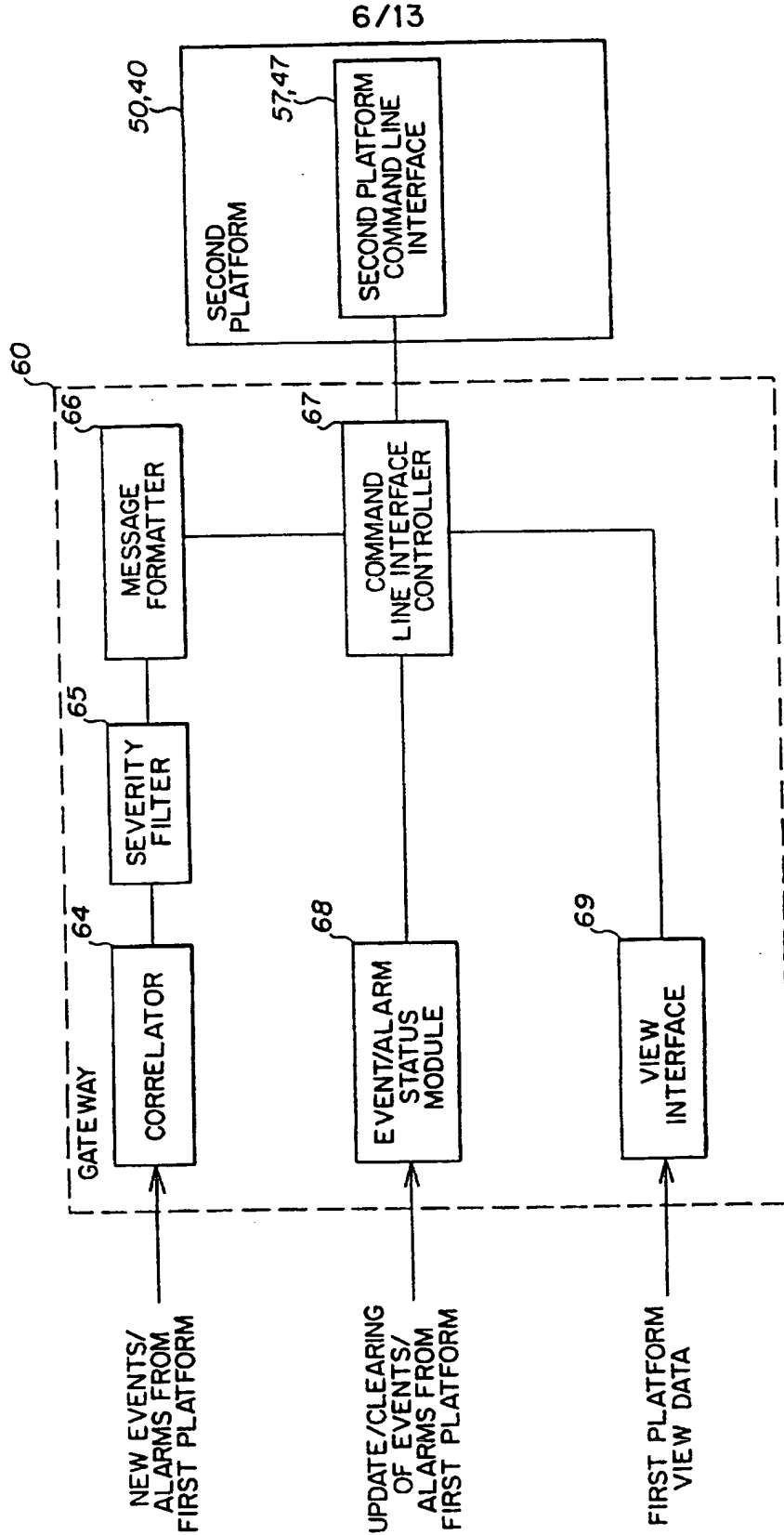

FIG. 6

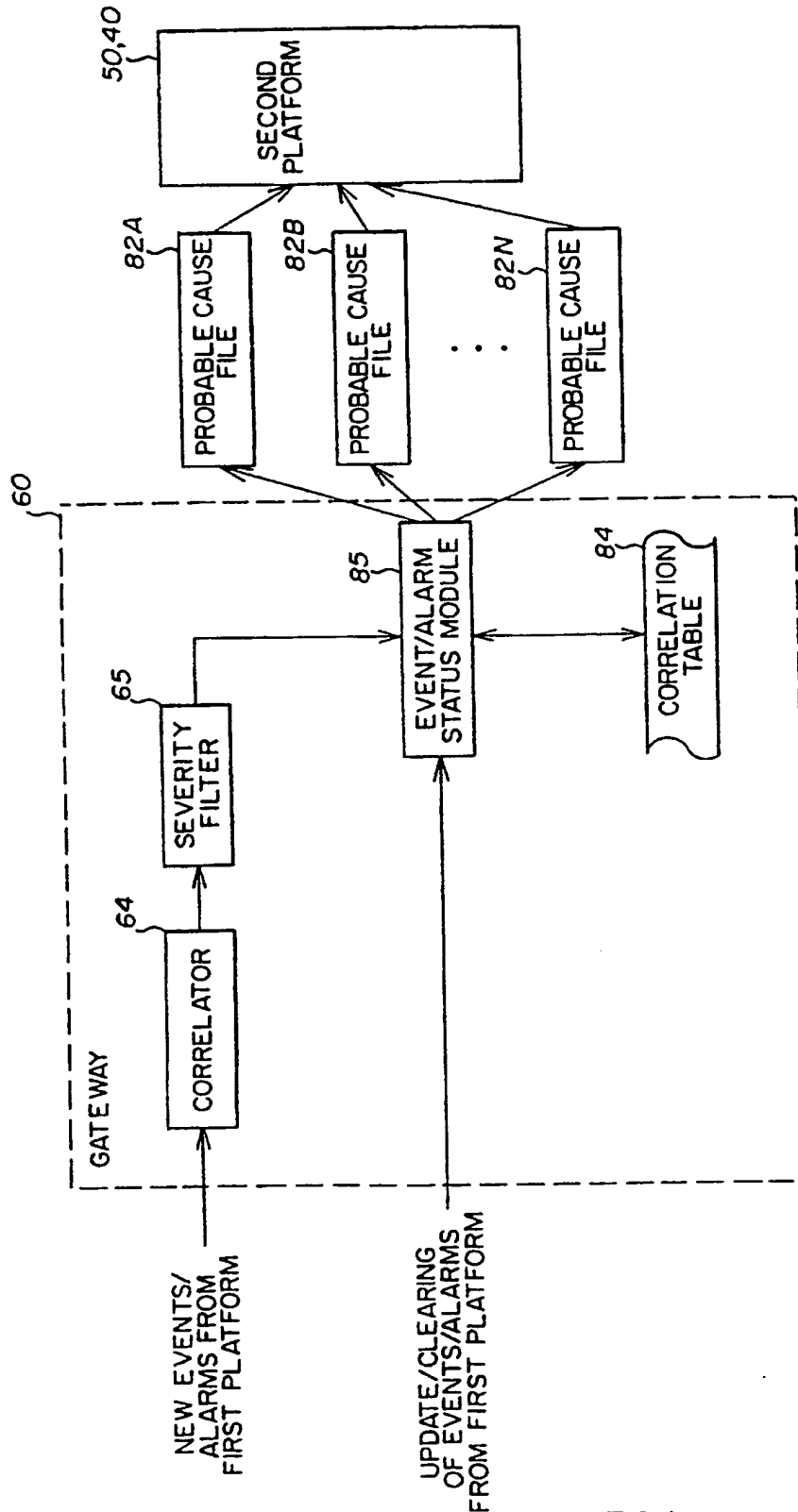

FIG. 8

Host name or model name	SPECTRUM model handle	Model IP address	Probable Cause file	Cause code	Parent model handle
sparkplug	0xe80007	134.141.145.64	Prob01550000	0x1550000	0xe80004
dolly	0xe80674	134.141.145.174	Prob01550001	0x1550001	0xe80004
brat	0xe80634	134.141.145.44	Prob01550002	0x1550002	0xe80004

FIG. 9

10/13

104

82

101

102

103

```
*** Begin Event 11808089408***  
DATE:      Aug 10, 1995 17:31  
MESSAGE:   NFS server (pid127@/NT/extinct) not responding  
SEVERITY:  CRITICAL  
***End Event 11808089408***  
  
***Begin Event 11808153595***  
DATE:     Aug 11 10:51:11  
MESSAGE:  su success: sharris->reynold  
SEVERITY: WARNING  
***End Event 11808153595***  
  
***Begin Event 11808155013***  
DATE:     Aug 11 11:21:29  
MESSAGE:  NFS server abbott not responding  
SEVERITY: WARNING  
***End Event 11808155013***
```

FIG. 10

SUBSTITUTE SHEET (RULE 28)

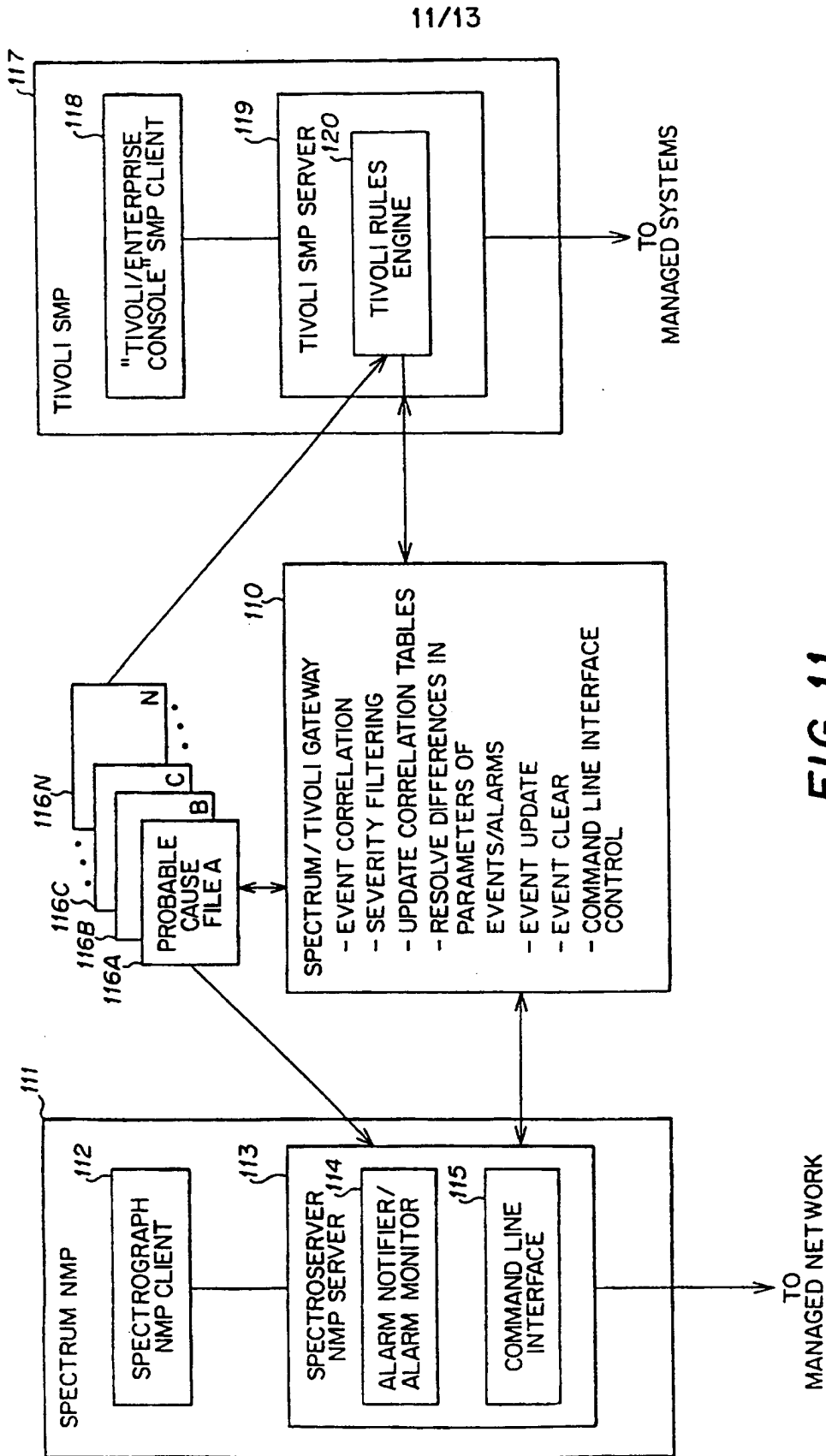

FIG. 11

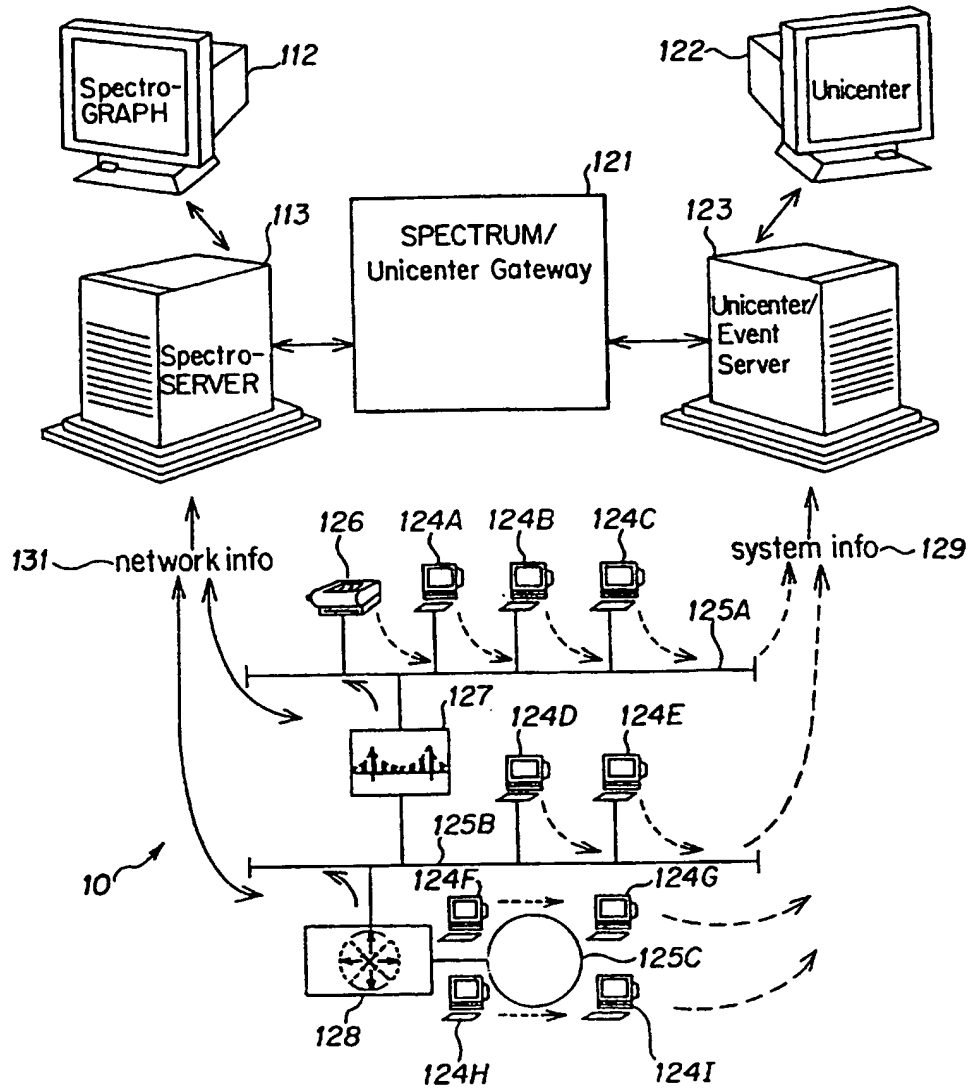

FIG. 12

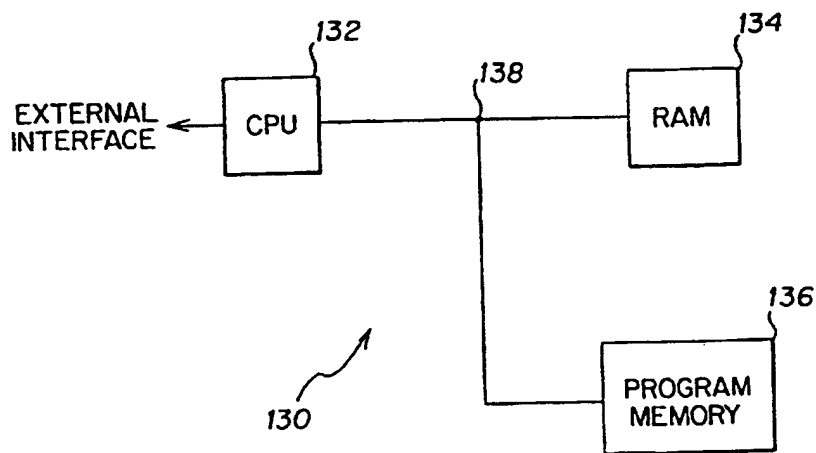

FIG. 13



INTERNATIONAL APPLICATION PUBLISHED UNDER THE PATENT COOPERATION TREATY (PCT)

<p>(51) International Patent Classification ⁶ : H04L 12/24</p>	<p>A3</p>	<p>(11) International Publication Number: WO 97/44937 (43) International Publication Date: 27 November 1997 (27.11.97)</p>
<p>(21) International Application Number: PCT/US97/08043 (22) International Filing Date: 13 May 1997 (13.05.97) (30) Priority Data: 08/649,278 17 May 1996 (17.05.96) US (71) Applicant: CABLETRON SYSTEMS, INC. [US/US]; 35 Industrial Way, P.O. Box 5005, Rochester, NH 03867-5005 (US). (72) Inventors: LEWIS, Lundy; 480 Greenville Road, Mason, NH 03048 (US). ST. ONGE, David; 110A Chestnut Street, Pepperell, MA 01463 (US). MEHTA, Ruchika; 18 Cummings Road, Monmouth Junction, NJ 08852 (US). (74) Agent: HENDRICKS, Therese, A.; Wolf, Greenfield & Sacks, P.C., 600 Atlantic Avenue, Boston, MA 02210 (US).</p>		<p>(81) Designated States: AL, AM, AT, AU, AZ, BA, BB, BG, BR, BY, CA, CH, CN, CU, CZ, DE, DK, EE, ES, FI, GB, GE, HU, IL, IS, JP, KE, KG, KP, KR, KZ, LC, LK, LR, LS, LT, LU, LV, MD, MG, MK, MN, MW, MX, NO, NZ, PL, PT, RO, RU, SD, SE, SG, SI, SK, TJ, TM, TR, TT, UA, UG, UZ, VN, ARIPO patent (GH, KE, LS, MW, SD, SZ, UG), Eurasian patent (AM, AZ, BY, KG, KZ, MD, RU, TJ, TM), European patent (AT, BE, CH, DE, DK, ES, FI, FR, GB, GR, IE, IT, LU, MC, NL, PT, SE), OAPI patent (BF, BJ, CF, CG, CI, CM, GA, GN, ML, MR, NE, SN, TD, TG). Published <i>With international search report. Before the expiration of the time limit for amending the claims and to be republished in the event of the receipt of amendments.</i> (88) Date of publication of the international search report: 31 December 1997 (31.12.97)</p>

(54) Title: METHOD AND APPARATUS FOR INTEGRATED NETWORK MANAGEMENT AND SYSTEMS MANAGEMENT IN COMMUNICATIONS NETWORKS

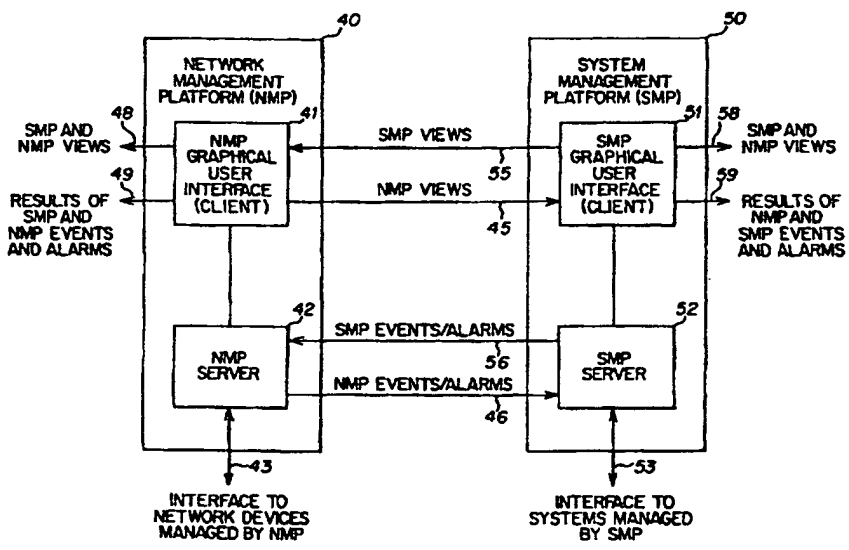

(57) Abstract

A computer system includes a gateway which provides integration between a network management platform and a system management platform. Such a gateway facilitates sharing of network management and system management events and alarms, as well as sharing of network management and system management display views. From the shared events and alarms, each platform may correlate such shared events and alarms with other data available to the platform. Thus, each platform has the advantage of using its own data in combination with data from the other platform to more effectively perform its functionality.

FOR THE PURPOSES OF INFORMATION ONLY

Codes used to identify States party to the PCT on the front pages of pamphlets publishing international applications under the PCT.

AL	Albania	ES	Spain	LS	Lesotho	SI	Slovenia
AM	Armenia	FI	Finland	LT	Lithuania	SK	Slovakia
AT	Austria	FR	France	LU	Luxembourg	SN	Senegal
AU	Australia	GA	Gabon	LV	Latvia	SZ	Swaziland
AZ	Azerbaijan	GB	United Kingdom	MC	Monaco	TD	Chad
BA	Bosnia and Herzegovina	GE	Georgia	MD	Republic of Moldova	TG	Togo
BB	Barbados	GH	Ghana	MG	Madagascar	TJ	Tajikistan
BE	Belgium	GN	Guinea	MK	The former Yugoslav Republic of Macedonia	TM	Turkmenistan
BF	Burkina Faso	GR	Greece	ML	Mali	TR	Turkey
BG	Bulgaria	HU	Hungary	MN	Mongolia	TT	Trinidad and Tobago
BJ	Benin	IE	Ireland	MR	Mauritania	UA	Ukraine
BR	Brazil	IL	Israel	MW	Malawi	UG	Uganda
BY	Belarus	IS	Iceland	MX	Mexico	US	United States of America
CA	Canada	IT	Italy	NE	Niger	UZ	Uzbekistan
CF	Central African Republic	JP	Japan	NL	Netherlands	VN	Viet Nam
CG	Congo	KE	Kenya	NO	Norway	YU	Yugoslavia
CH	Switzerland	KG	Kyrgyzstan	NZ	New Zealand	ZW	Zimbabwe
CI	Côte d'Ivoire	KP	Democratic People's Republic of Korea	PL	Poland		
CM	Cameroon	KR	Republic of Korea	PT	Portugal		
CN	China	KZ	Kazakistan	RO	Romania		
CU	Cuba	LC	Saint Lucia	RU	Russian Federation		
CZ	Czech Republic	LI	Liechtenstein	SD	Sudan		
DE	Germany	LK	Sri Lanka	SE	Sweden		
DK	Denmark	LR	Liberia	SG	Singapore		
EE	Estonia						

INTERNATIONAL SEARCH REPORT

Internat'l Application No
PCT/US 97/08043

A. CLASSIFICATION OF SUBJECT MATTER IPC 6 H04L12/24				
According to International Patent Classification (IPC) or to both national classification and IPC				
B. FIELDS SEARCHED				
Minimum documentation searched (classification system followed by classification symbols) IPC 6 H04L H04Q				
Documentation searched other than minimum documentation to the extent that such documents are included in the fields searched				
Electronic data base consulted during the international search (name of data base and, where practical, search terms used)				
C. DOCUMENTS CONSIDERED TO BE RELEVANT				
Category *	Citation of document, with indication, where appropriate, of the relevant passages	Relevant to claim No.		
X	WO 95 08794 A (CODEX, INC.) 30 March 1995 see page 2, line 2 - line 18 see page 6, line 10 - line 25 see page 9, line 8 - line 13 see page 10, line 14 - line 17 --- -/--	1-3, 11-13, 21,22		
<input checked="" type="checkbox"/> Further documents are listed in the continuation of box C.				
<input checked="" type="checkbox"/> Patent family members are listed in annex.				
* Special categories of cited documents :				
<table style="width: 100%; border: none;"> <tr> <td style="width: 50%; border: none; vertical-align: top;"> *A* document defining the general state of the art which is not considered to be of particular relevance *E* earlier document but published on or after the international filing date *L* document which may throw doubts on priority claim(s) or which is cited to establish the publication date of another citation or other special reason (as specified) *O* document referring to an oral disclosure, use, exhibition or other means *P* document published prior to the international filing date but later than the priority date claimed </td> <td style="width: 50%; border: none; vertical-align: top;"> *T* later document published after the international filing date or priority date and not in conflict with the application but cited to understand the principle or theory underlying the invention *X* document of particular relevance; the claimed invention cannot be considered novel or cannot be considered to involve an inventive step when the document is taken alone *Y* document of particular relevance; the claimed invention cannot be considered to involve an inventive step when the document is combined with one or more other such documents, such combination being obvious to a person skilled in the art. *Z* document member of the same patent family </td> </tr> </table>			*A* document defining the general state of the art which is not considered to be of particular relevance *E* earlier document but published on or after the international filing date *L* document which may throw doubts on priority claim(s) or which is cited to establish the publication date of another citation or other special reason (as specified) *O* document referring to an oral disclosure, use, exhibition or other means *P* document published prior to the international filing date but later than the priority date claimed	*T* later document published after the international filing date or priority date and not in conflict with the application but cited to understand the principle or theory underlying the invention *X* document of particular relevance; the claimed invention cannot be considered novel or cannot be considered to involve an inventive step when the document is taken alone *Y* document of particular relevance; the claimed invention cannot be considered to involve an inventive step when the document is combined with one or more other such documents, such combination being obvious to a person skilled in the art. *Z* document member of the same patent family
A document defining the general state of the art which is not considered to be of particular relevance *E* earlier document but published on or after the international filing date *L* document which may throw doubts on priority claim(s) or which is cited to establish the publication date of another citation or other special reason (as specified) *O* document referring to an oral disclosure, use, exhibition or other means *P* document published prior to the international filing date but later than the priority date claimed	*T* later document published after the international filing date or priority date and not in conflict with the application but cited to understand the principle or theory underlying the invention *X* document of particular relevance; the claimed invention cannot be considered novel or cannot be considered to involve an inventive step when the document is taken alone *Y* document of particular relevance; the claimed invention cannot be considered to involve an inventive step when the document is combined with one or more other such documents, such combination being obvious to a person skilled in the art. *Z* document member of the same patent family			
Date of the actual completion of the international search 5 November 1997	Date of mailing of the international search report 18.11.97			
Name and mailing address of the ISA European Patent Office, P.B. 5818 Patentlaan 2 NL - 2280 HV Rijswijk Tel. (+31-70) 340-2040, Tx. 31 651 epo nl, Fax: (+31-70) 340-3016		Authorized officer Larcinese, C		

INTERNATIONAL SEARCH REPORT

International Application No
PCT/US 97/08043

C.(Continuation) DOCUMENTS CONSIDERED TO BE RELEVANT		
Category *	Citation of document, with indication, where appropriate, of the relevant passages	Relevant to claim No.
A	<p>SCHLAERTH J P: "A CONCEPT FOR TACTICAL WIDE-AREA NETWORK HUB MANAGEMENT" PROCEEDINGS OF THE MILITARY COMMUNICATIONS CONFERENCE (MILCOM), LONG BRANCH, NJ., OCT. 2 - 5, 1994, vol. 2 OF 3, 2 October 1994, INSTITUTE OF ELECTRICAL AND ELECTRONICS ENGINEERS, pages 644-649, XP000505952 see page 645, right-hand column, line 45 - line 57 see page 646, left-hand column, line 5 - line 7 see page 646, line 10 - line 15 see page 647, right-hand column, line 32 - line 39; figure 5</p>	1-30
A	<p style="text-align: center;">---</p> <p>WO 94 23514 A (BRITISH TELECOMMUNICATIONS PUBLIC LIMITED COMPANY) 13 October 1994 see page 1, line 11 - line 19 see page 1, line 30 - page 2, line 2 see page 6, line 4 - line 10 see page 40, line 1 - line 25; figure 1</p>	1,11,21
A	<p style="text-align: center;">---</p> <p>EP 0 632 617 A (ALCATEL N.V.) 4 January 1995 see column 3, line 28 - line 31 see column 5, line 23 - line 38 see column 8, line 29 - line 39</p>	1,11,21
A	<p style="text-align: center;">---</p> <p>EP 0 621 716 A (NORTHERN TELECOM LIMITED) 26 October 1994 see abstract see column 1, line 24 - line 34 see column 3, line 36 - line 50; figure 1</p> <p style="text-align: center;">-----</p>	1,11,21

1

INTERNATIONAL SEARCH REPORT

Information on patent family members

Intern. Application No

PCT/US 97/08043

Patent document cited in search report	Publication date	Patent family member(s)	Publication date
WO 9508794 A	30-03-95	AU 7558094 A	10-04-95
		CA 2148603 A	30-03-95
		EP 0670060 A	06-09-95
WO 9423514 A	13-10-94	CA 2159001 A	13-10-94
		EP 0691056 A	10-01-96
		JP 8508376 T	03-09-96
EP 632617 A	04-01-95	DE 4321458 A	12-01-95
EP 621716 A	26-10-94	GB 2277229 A	19-10-94
		CA 2121114 A	18-10-94
		US 5652787 A	29-07-97